

Assembly Manual

Fleet-Recorder (5305.00)

Introduction

Foreword

The installation procedures described in this assembly manual should only be undertaken by a Hako service centre or a workshop authorised by Hako. Members of staff with the required level of training and expertise are only guaranteed in the said workshops. This assembly manual may be used only in conjunction with the machine's operating manual.

Safety instructions

With regard to handling and operation, please observe the general safety regulations of the corresponding machine in the relevant operating manual. Place the machine on a level surface and hold it with the parking brake. Disconnect the battery plug.

We would expressly advise you that no legal claims may be asserted based on the contents of these instructions. In the case of necessary repair work, please make sure that only original spare parts are used. Only original spare parts guarantee constant and reliable operational readiness of your machine. We reserve the right to make changes in the interests of further technical development.

Valid as from: January 2016

Hako GmbH
23843 Bad Oldesloe, Germany
Hamburger Str. 209-239
Phone +49 4531 806-0

This assembly manual applies to all variants of the
Scrubmaster B75 R and
Scrubmaster B115 R.

1 Fleet-Recorder Scrubmaster B75 R

1.1 Parts list

- 1 Fleet-Recorder
- 2 I-Button-Reader
- 3 User key
- 4 Antenna
- 5 Buzzer
- 6 Label

Parts not displayed:
1x W77 cable loom
1x fuse insert
1x O-ring

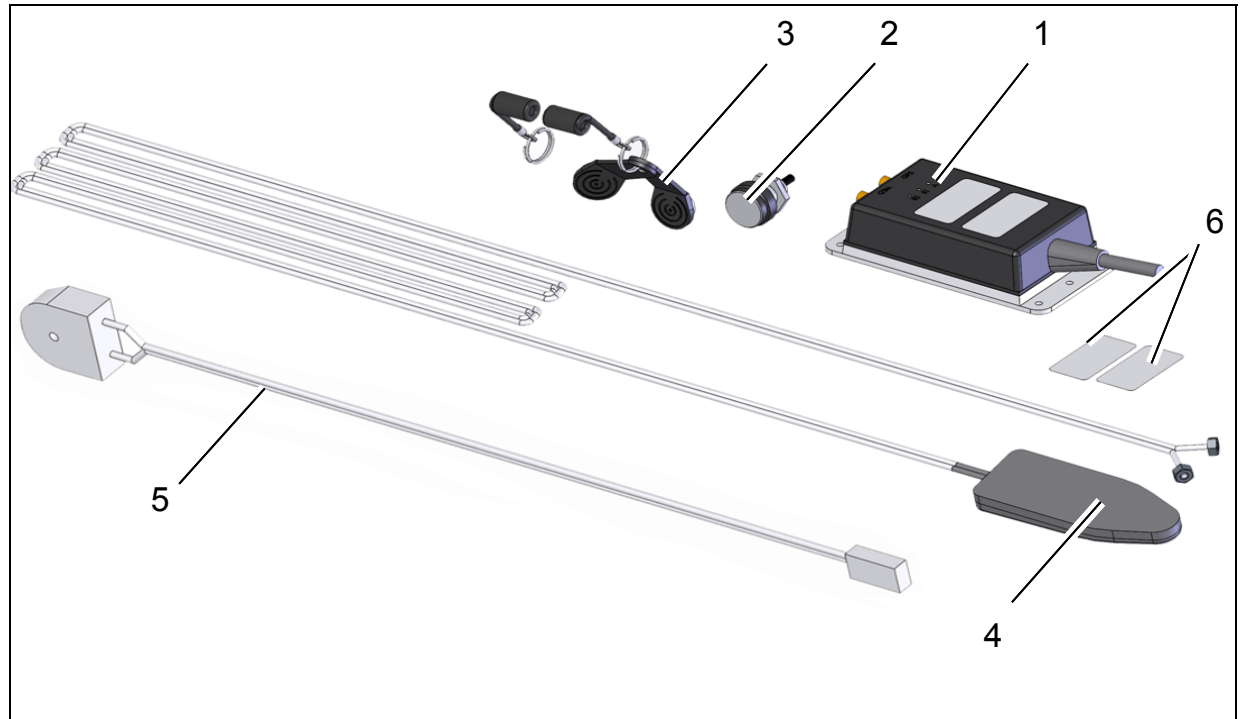

Fig. 1

Fleet-Recorder Scrubmaster B75 R

1.2 Installing the Fleet-Recorder Scrubmaster B75 R



Caution

Prior to installation, place the machine on a level surface, secure it against rolling away and disconnect the battery plug!



Make all the electrical connections according to the circuit diagram of the respective machine variant.

1.2.1 Installing the I-Button-Reader

1. Use the extractor to disassemble the steering wheel.
2. Disassemble the control panel.
3. Cut into the film in the area of the right-hand hole on the rear of the control panel (Fig. 2/1).
4. Install the I-Button-Reader.
5. Connect the plug of the I-Button-Reader to the 4-pole plug B20/X1 of the existing W60 cable loom (Fig. 2/2).
6. Reinstall the control panel and the steering wheel.
7. Position the RFID lock sticker underneath the I-Button-Reader.

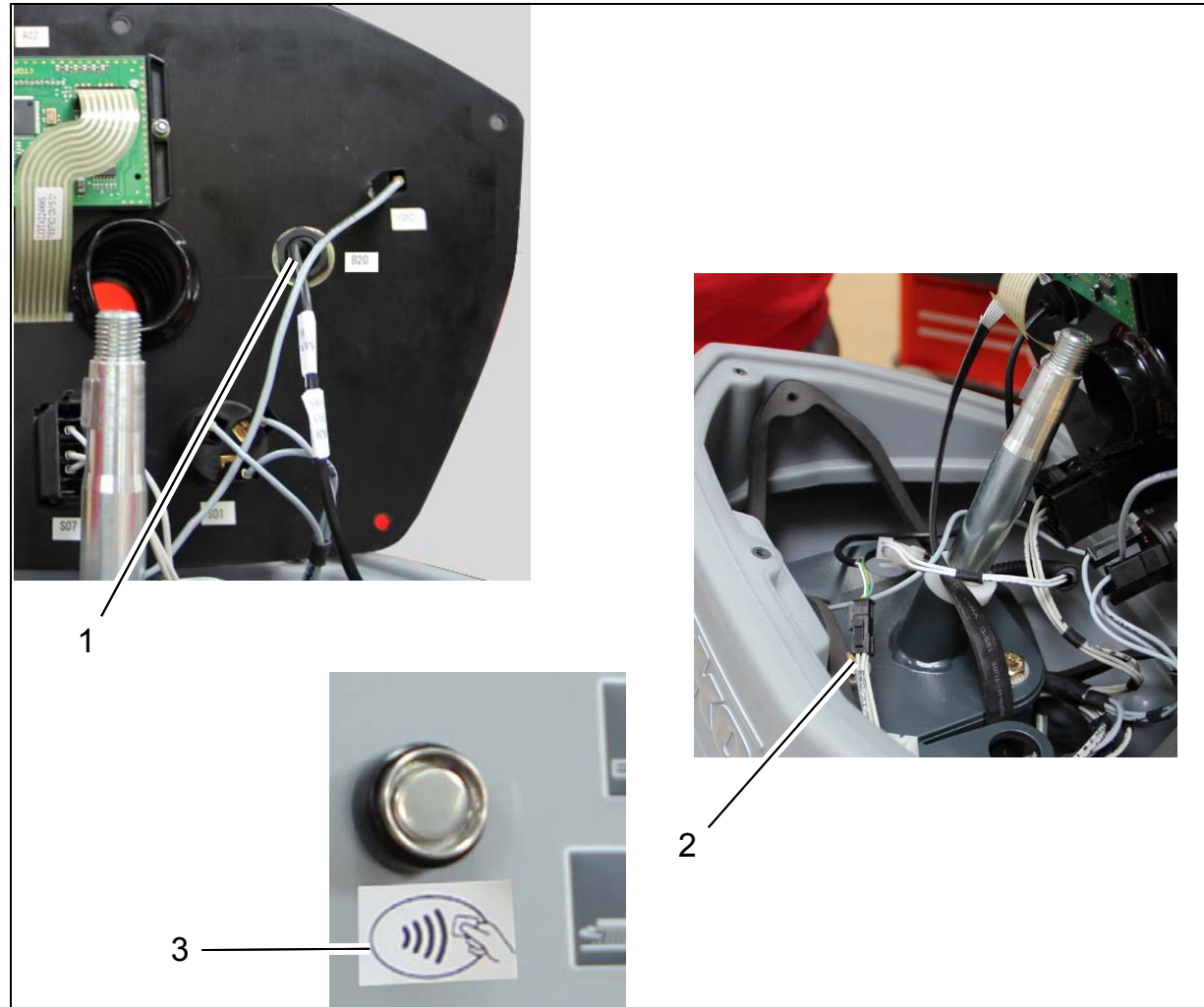

Fig. 2

1.2.2 Installing the antenna and the Fleet-Recorder

1. Clean the surface of the seat console to the right of the driver's seat.
2. Use the sticker to fix the antenna at a distance of 140 mm to the rear wall (Fig. 3/1).
3. Route the antenna cable through the ventilation slots of the seat console (Fig. 3/2).
4. Route the cable in a protective tube along the seat contact switch cable into the electronics compartment (Fig. 3/3).
5. Attach the Fleet-Recorder (Fig. 3/4) to the holder using an O-ring (Fig. 3/5).
6. Connect the antenna cable to the GPS and the GSM connections of the Fleet-Recorder (Fig. 3/6) according to the labelling.

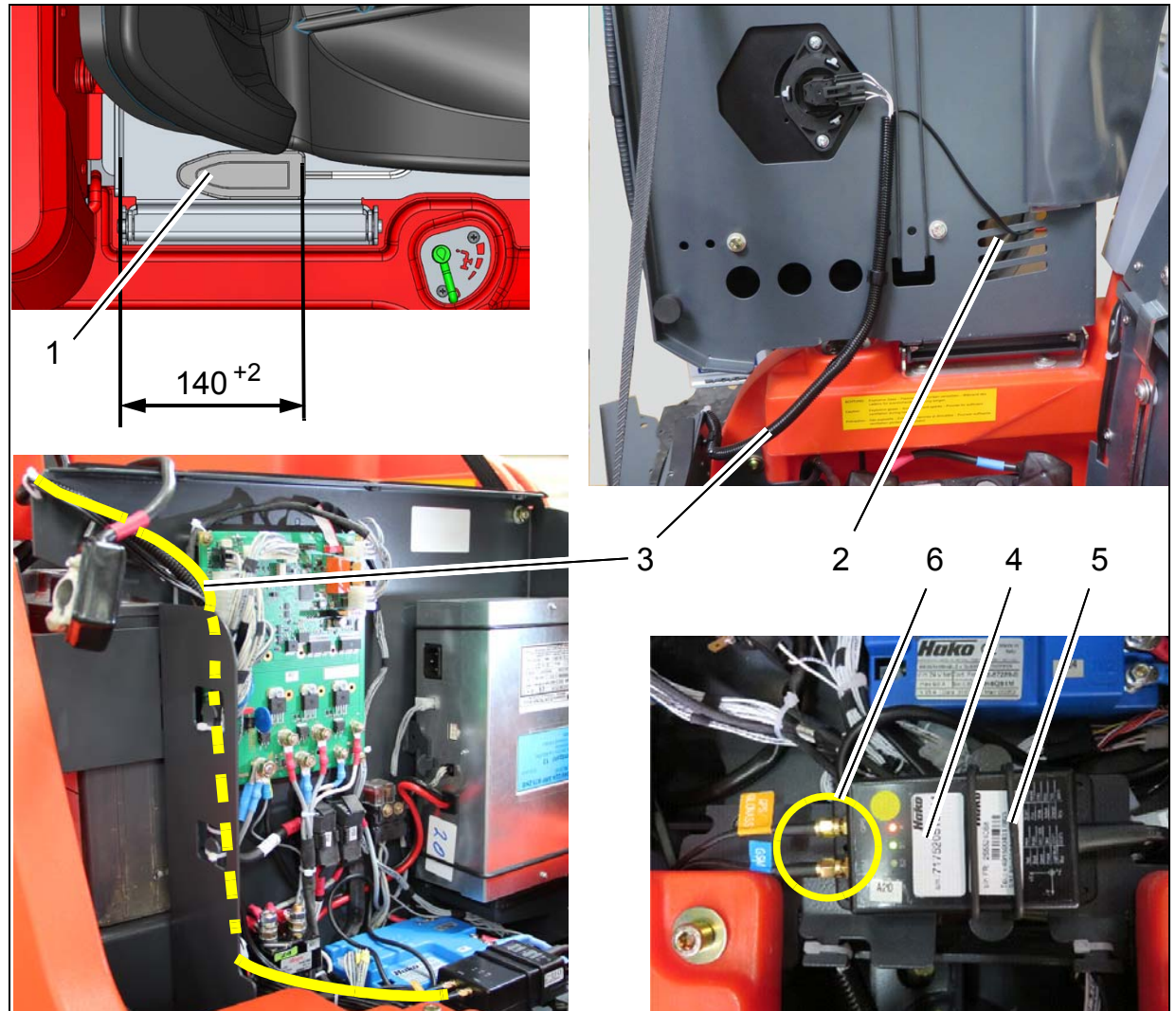

Fig. 3

Fleet-Recorder Scrubmaster B75 R

1.2.3 Installing the buzzer



The connection lines of the buzzer are sensitive to tension stress!

Use cable ties at a distance of > 50 mm to the buzzer.

Run the antenna cable (Fig. 4/1) in a loop and fix it together with the P20 buzzer (Fig. 4/2) using cable ties (Fig. 4/3).

1.2.4 Installing the W77 cable loom

1. Insert the 6-pole plug A01/X3 of the W77 cable loom into the diagnosis slot of control A01 (Fig. 4/4).
2. Connect the plug of the P20 buzzer to the plug of the W77 cable loom (Fig. 4/5).
3. Connect the 4-pole plug X78 of the W77 cable loom to the same named plug of the W60 cable loom.
4. Connect the plug of the Fleet-Recorder A20/X1 to the 12-pole plug of the W77 cable loom.
5. To connect to the key switch, connect plug X102 of the W77 cable loom to the same named plug of the W3 cable loom.

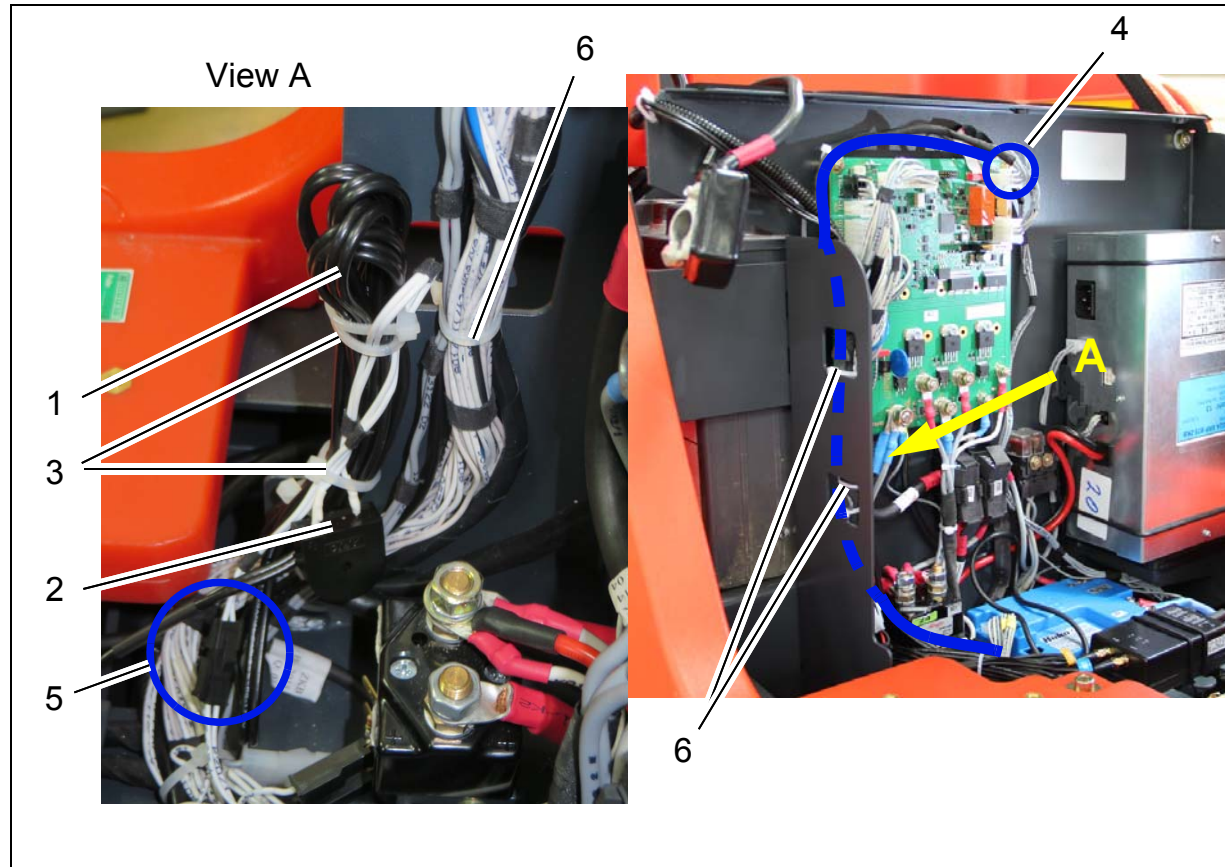

Fig. 4

6. Establish earth connection with X41.
7. Use cable ties to fix the W77 cable loom to the chassis (Fig. 4/6).
8. Establish a connection to fuse F20 (Fig. 5/1). Insert the fuse insert 5A into the fuse holder (Fig. 5/2).
9. Plug connector XK01/A1 is not connected. Fix the plug connector to the W3 cable loom using cable ties (Fig. 5/3).
10. Plug connectors X106 and X107 are not connected. Run the lines of the plug connectors in loops and fix them to the W77 cable loom using cable ties (Fig. 5/4).

1.3 Putting into service

The machine specific settings for putting the Fleet-Recorder into service are carried out by the technical customer service.

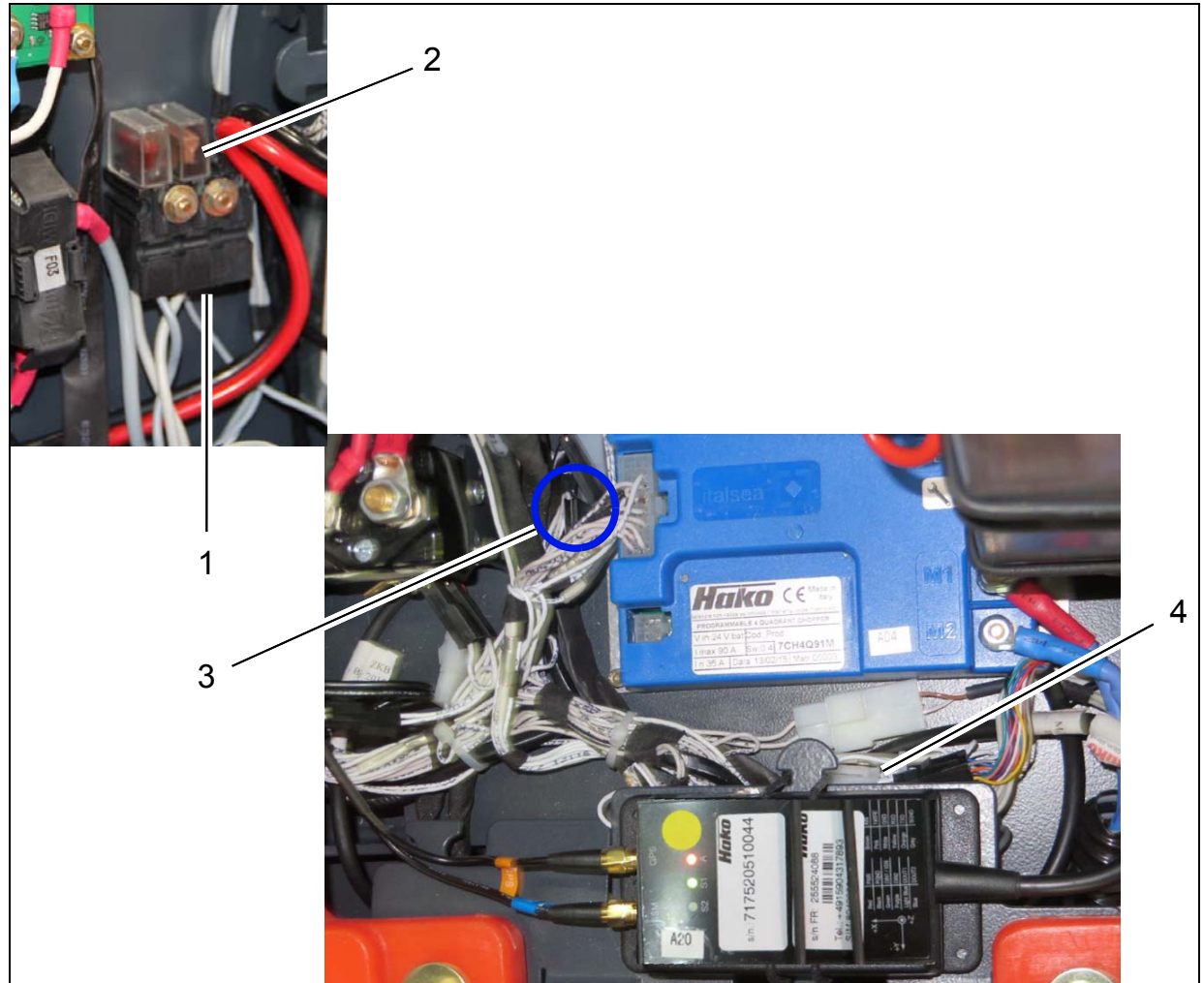
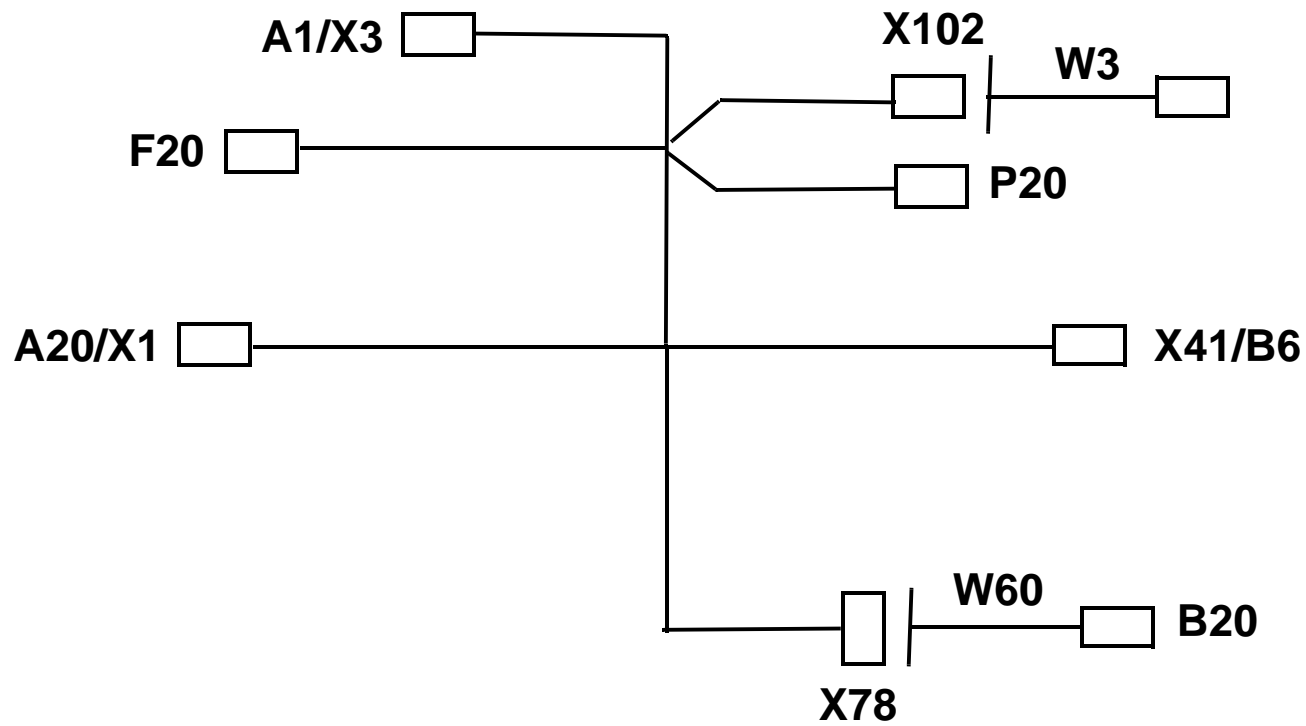

Fig. 5

Fleet-Recorder Scrubmaster B75 R

1.4 Schematic diagram of the W77 cable loom (Scrubmaster B75 R)



2 Fleet-Recorder Scrubmaster B115 R

2.1 Parts list

- 1 Fleet-Recorder
- 2 I-Button-Reader
- 3 User key
- 4 Antenna
- 5 Buzzer
- 6 Label
- 7 Plate
- 8 Holder

Parts not displayed:
1x W77 cable loom
1x W78 cable loom
1x W79 cable loom
1x fuse insert
1x O-ring
2x sheet-metal screw

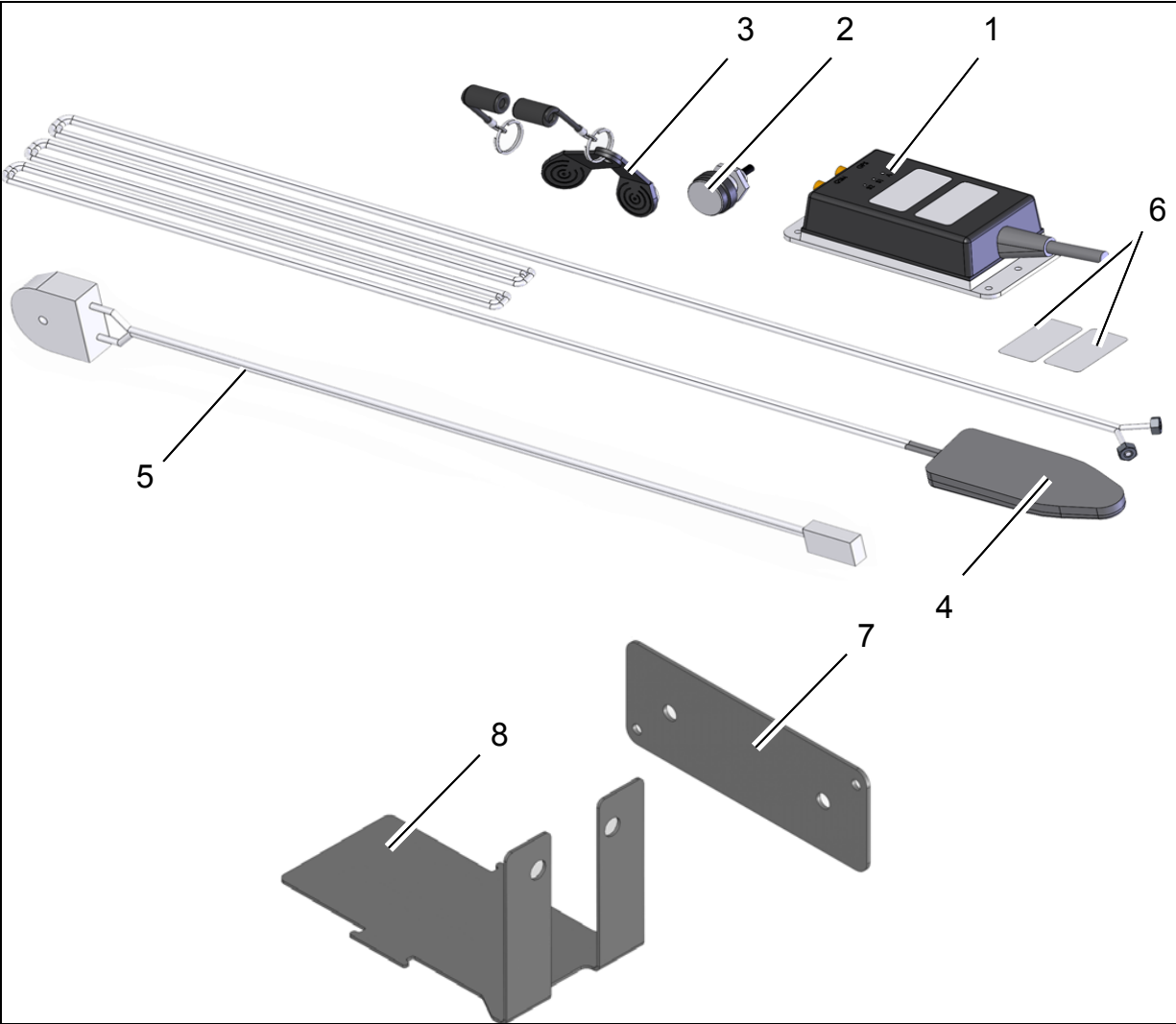

Fig. 6

Fleet-Recorder Scrubmaster B115 R

2.2 Installing the Fleet-Recorder B115 R



Caution

Prior to installation, place the machine on a level surface, secure it against rolling away and disconnect the battery plug!



Make all the electrical connections according to the circuit diagram of the respective machine variant.

2.2.1 Installing the I-Button-Reader

1. Disassemble the control panel on the left-hand side (Fig. 7/1).
2. Cut into the film in the area of the top left hole on the rear of the control panel (Fig. 7/2).
3. Install the I-Button-Reader.
4. Connect the plug of the I-Button-Reader to the 4-pole plug B20/X1 of the W78 cable loom (Fig. 7/3).
5. Attach the cable end of the I-Button-Reader to the available cable loom using cable ties.
6. Route the W78 cable loom on the left of the steering column downwards.
7. Re-install the control panel.

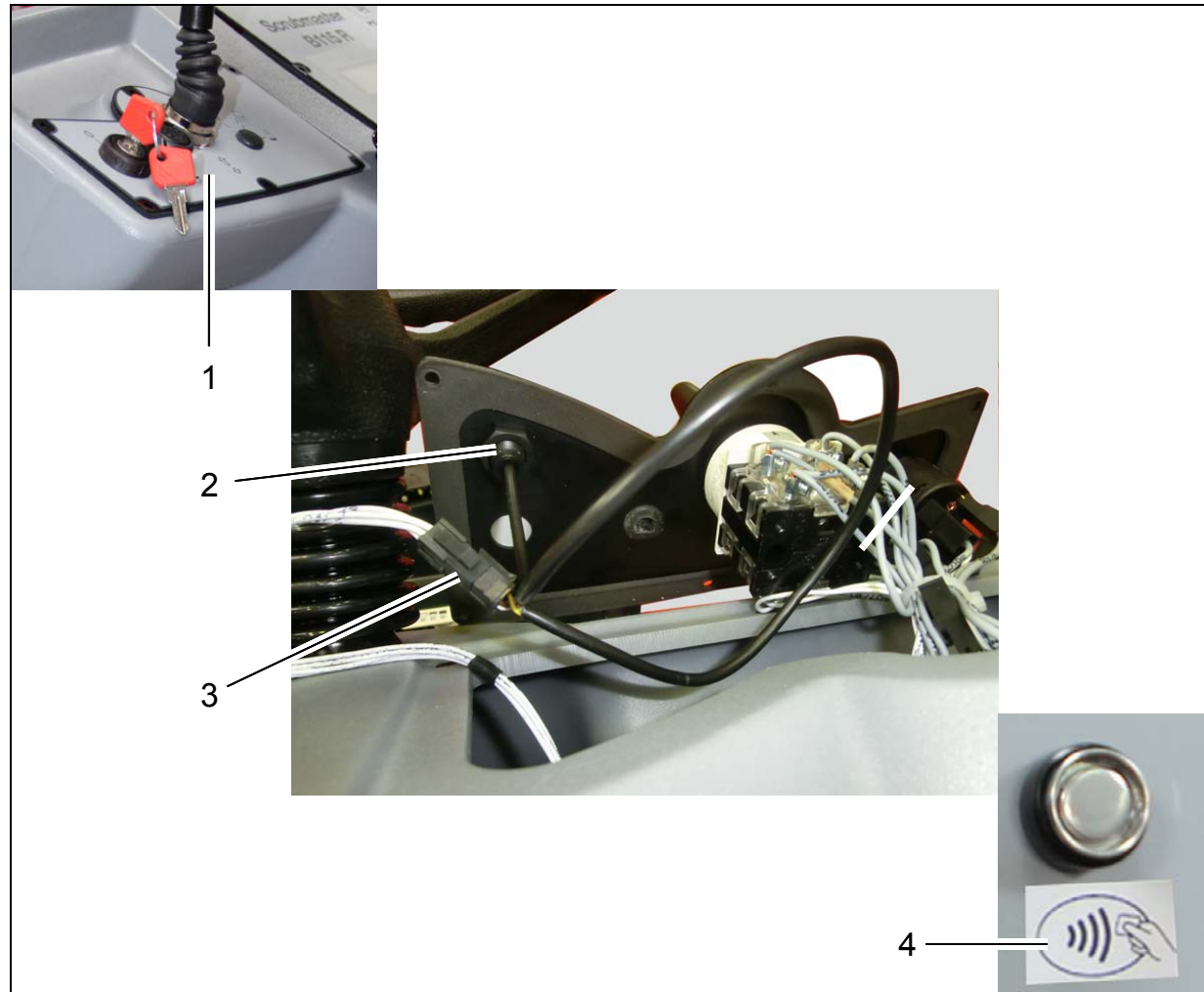

Fig. 7

8. Position the RFID lock sticker underneath the I-Button-Reader (Fig. 7/4).

2.2.2 Routing the W78 cable loom

1. Disassemble the hood of the steering column (Fig. 8/1) and the brake pedal (Fig. 8/2).
2. Route the W78 cable loom (Fig. 8/3) laterally along the inside of the steering column and fix it using cable ties (Fig. 8/4).
3. Run the W78 cable loom in front of the brake pedal (Fig. 8/5) and route it into the electronics compartment.
4. In the electronics compartment, route the W78 cable loom through the available cable ties (Fig. 8/6).

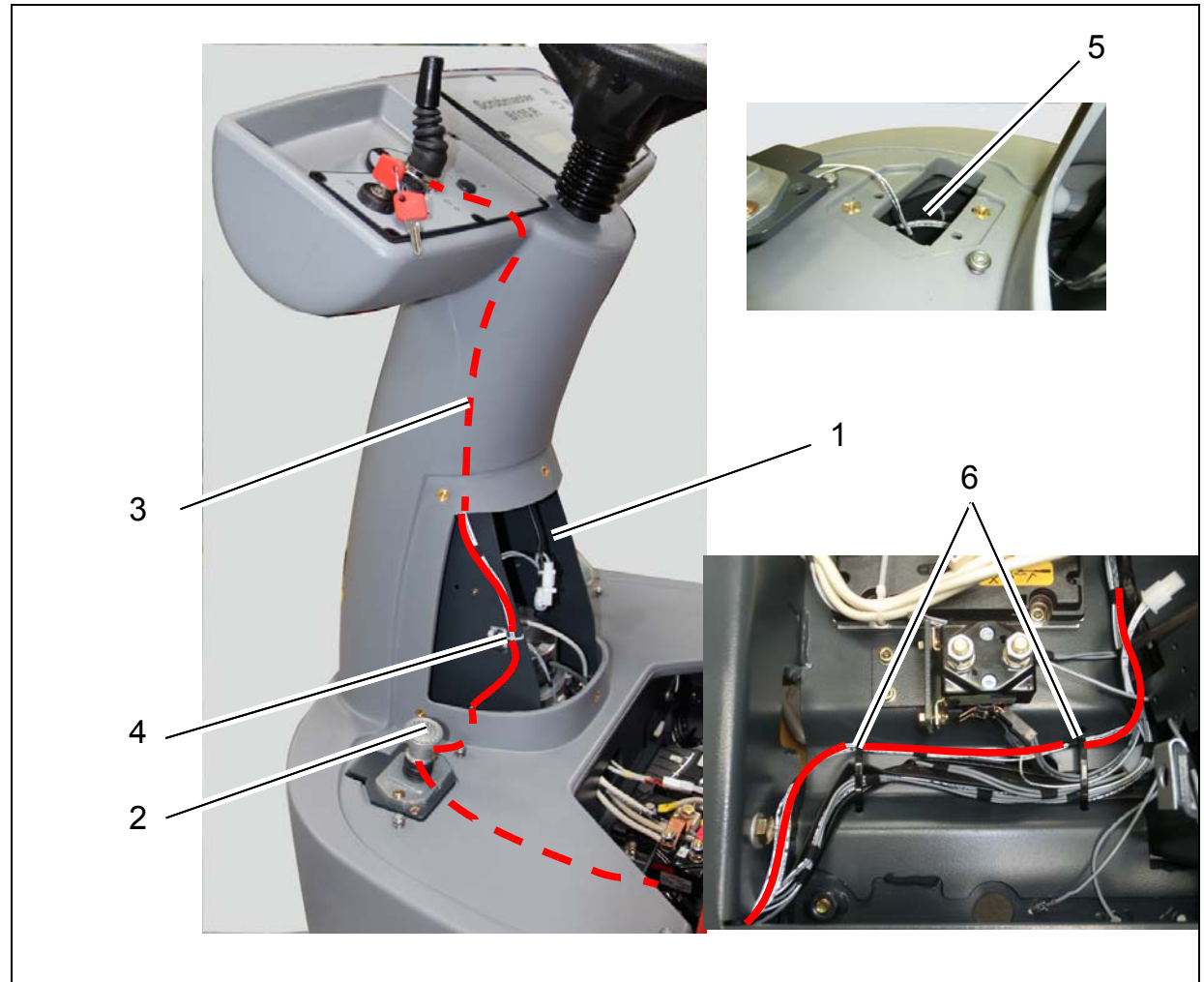

Fig. 8

Fleet-Recorder Scrubmaster B115 R

2.2.3 Installing the antenna

Prior to installing the antenna, remove the batteries.



Caution

Only use suitable lifting equipment to remove/insert batteries!

1. Install the plate at the rear wall of the seat shell using two sheet-metal screws according to the sketch (Fig. 9/1).
2. Clean the adhesive surface and use the sticker to fix the antenna to the plate (Fig. 9/2).
3. Guide the antenna cable through the hole in the centre of the seal shell (Fig. 9/3).
4. Route the antenna cable along the seat contact switch cable (Fig. 9/4).
5. Route the antenna cable at the bottom of the battery compartment through the available cable ties into the electronics compartment (Fig. 9/5).
6. Use cable ties to fix the antenna cable along the route.

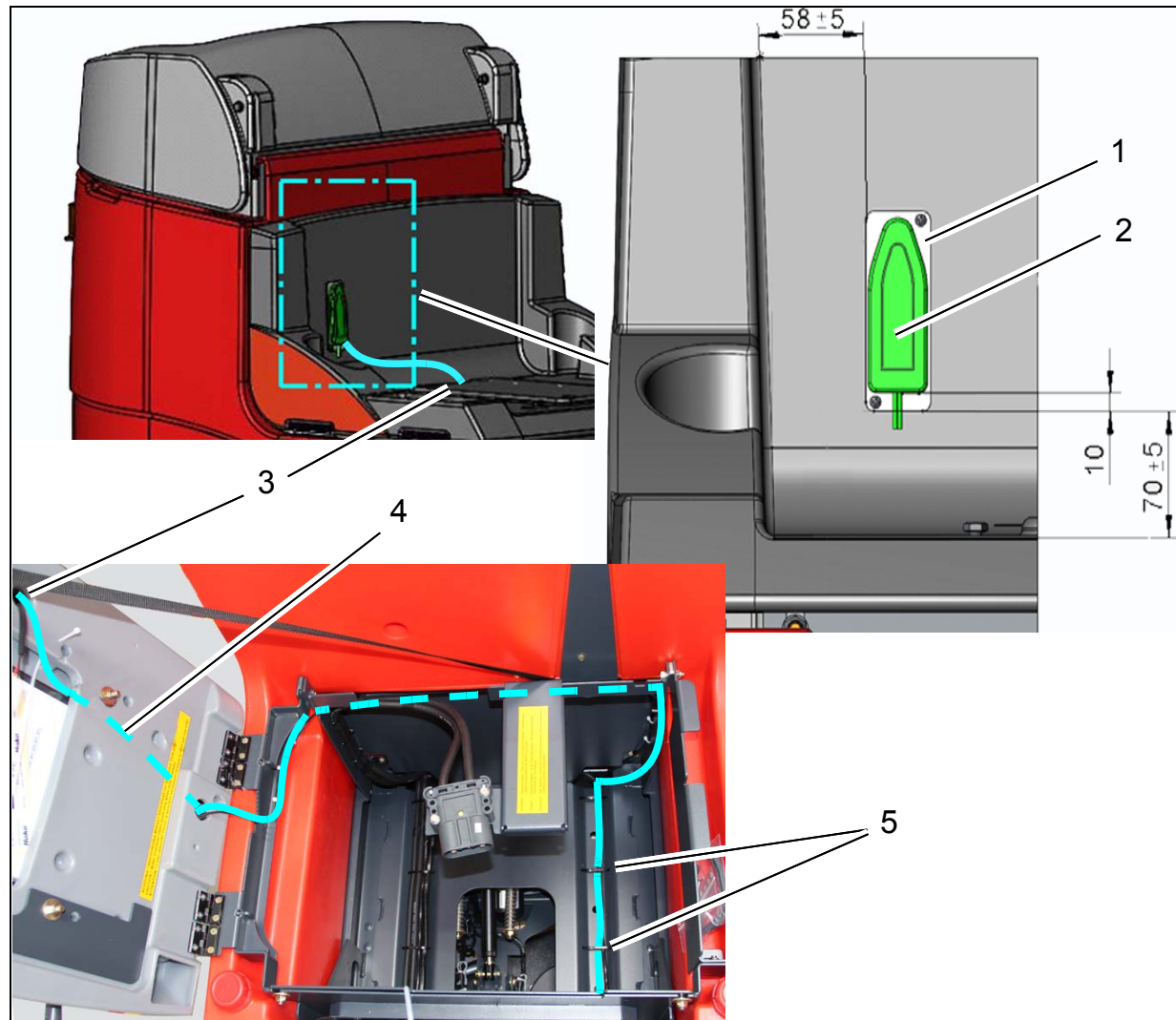

Fig. 9

2.2.4 Installing the Fleet-Recorder

1. Attach the holder for the Fleet-Recorder in the electronics compartment using the available screws and washers (Fig. 10/1).
2. Fix the Fleet-Recorder to the holder using the O-ring (Fig. 10/2).
3. Connect the antenna cable to the GPS and the GSM connections of the Fleet-Recorder (Fig. 10/3) according to the labelling.
4. Run the cable of the Fleet-Recorder back into the electronics compartment.

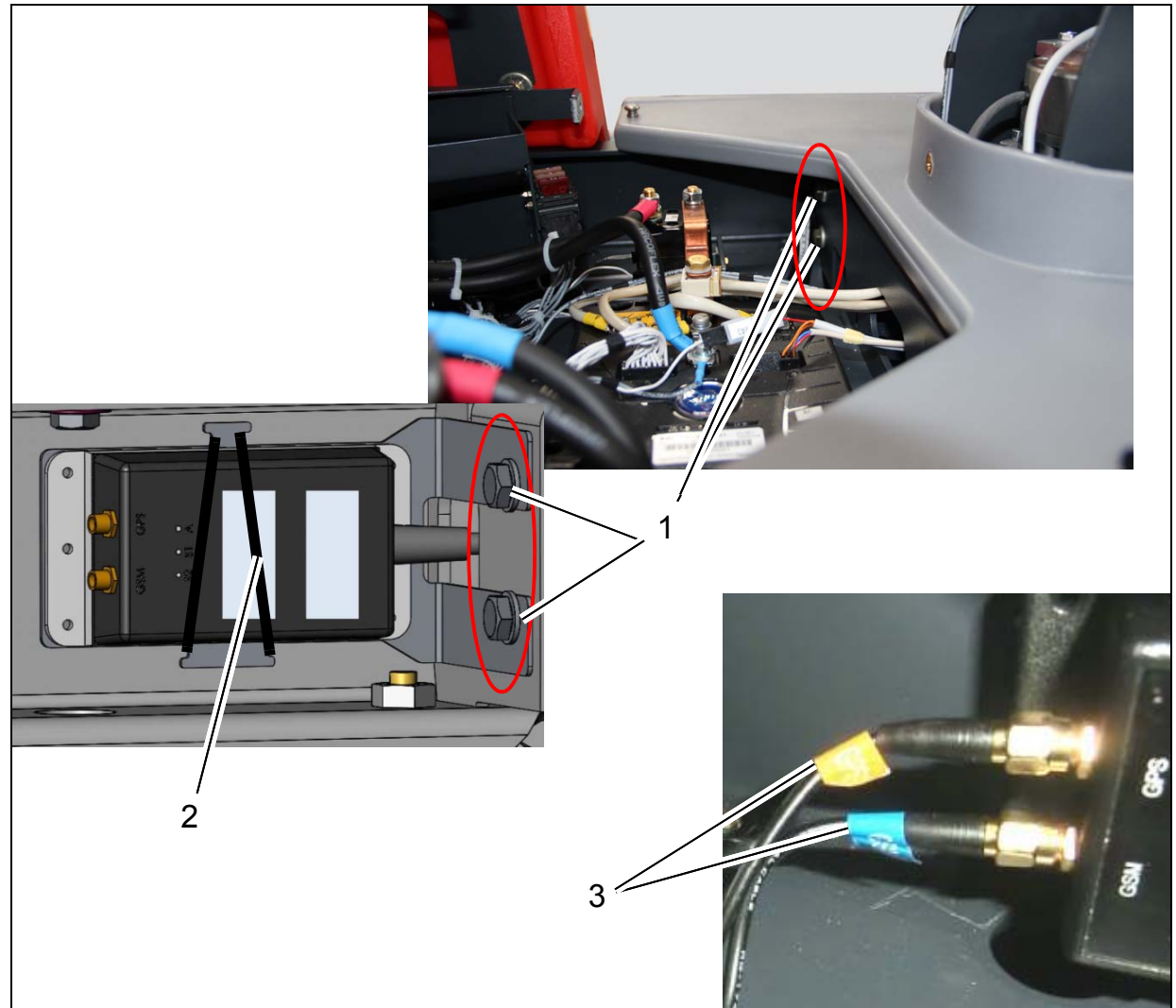

Fig. 10

Fleet-Recorder Scrubmaster B115 R

2.2.5 Connections of the W79 cable loom

1. Connections for the variant with on-board charger and relay K01:

- Connect XK01/A1 to the second connection of K01/A1 (Fig. 11/1).
- X102 is not connected.
- Ring cable lug of connection K01/K1 (Fig. 11/2).
- Ring cable lug of connection K01/K3 (Fig. 11/3)
- Connect the plug X4/B6 to the plug of the W77 cable loom (Fig. 11/4).

2. Connections for the variant without on-board charger:

- Connect X102 to plug K01/A1.
- XK01A1 is not connected.

3. Attach fuse holder F20 from the W79 cable loom on the right next to fuse holder F7 (Fig. 11/5).

4. Insert fuse insert 5A into the fuse holder (Fig. 11/6) and affix the sticker (Fig. 11/7).

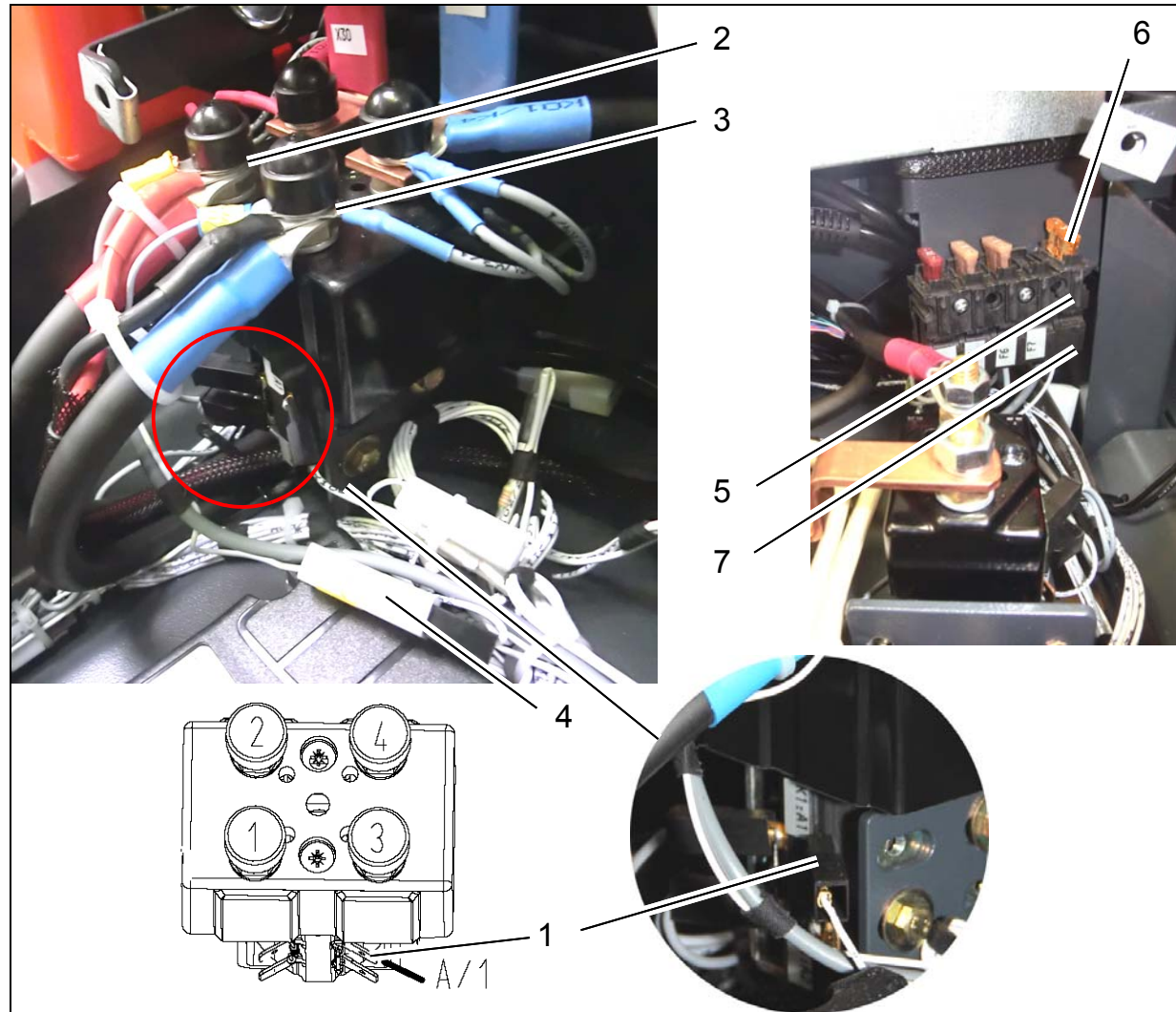

Fig. 11

2.2.6 Installing the buzzer



The connection lines of the buzzer are sensitive to tension stress!

Use cable ties at a distance of > 50 mm to the buzzer.

Run the cable of the P20 buzzer in a loop and fix it to the W77 cable loom using cable ties (Fig. 12/1).

2.2.7 Connections of the W77 cable loom

1. Insert the 6-pole plug A01/X3 of the W77 cable loom into the diagnosis slot of the control (Fig. 12/1).
2. Connect the plug of the P20 buzzer to the plug of the W77 cable loom.
3. Connect the plug A20/X1 of the Fleet-Recorder to the 12-pole plug of the W77 cable loom (Fig. 12/2).
4. Connect the 4-pole plug X78 of the W77 cable loom to the plug of the W78 cable loom.
5. Establish a connection to fuse F20 (Fig. 12/3).

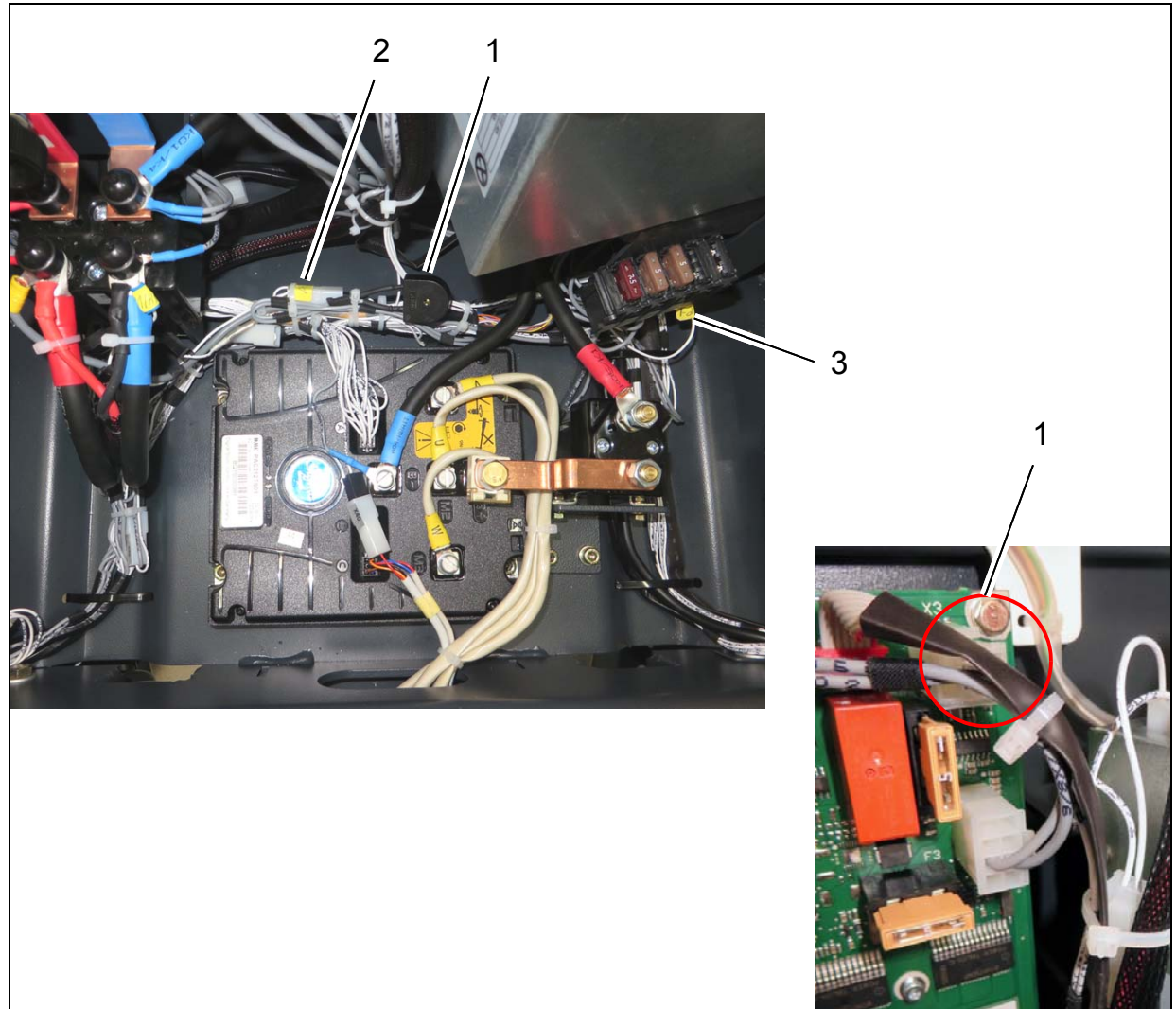

Fig. 12

Fleet-Recorder Scrubmaster B115 R

6. Connect the plug connector X106 to plug G02/x1 of the W2 cable loom and fix it using cable ties (Fig. 13/1).
7. Connect the plug connector X107 to X1 of the charger G02 (Fig. 13/2).

2.3 Putting into service

The machine specific settings for putting the Fleet-Recorder into service are carried out by the technical customer service.

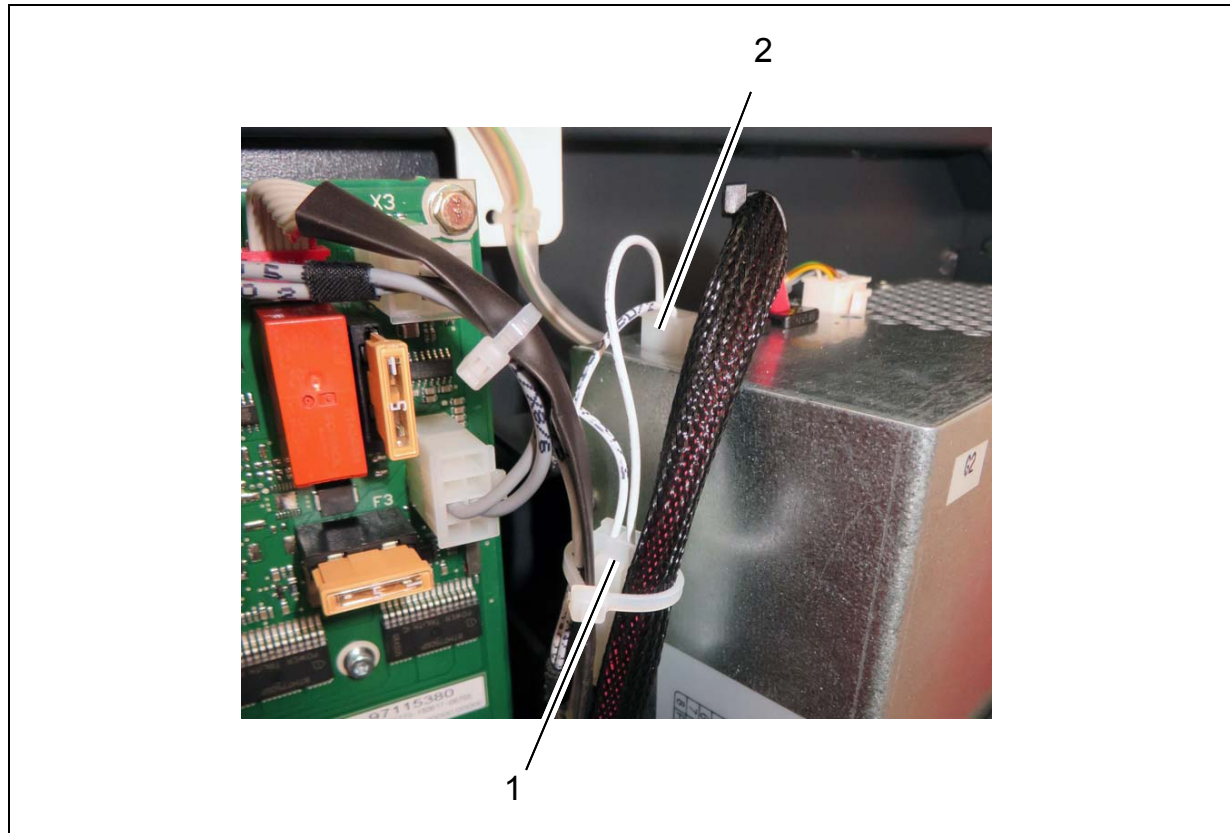
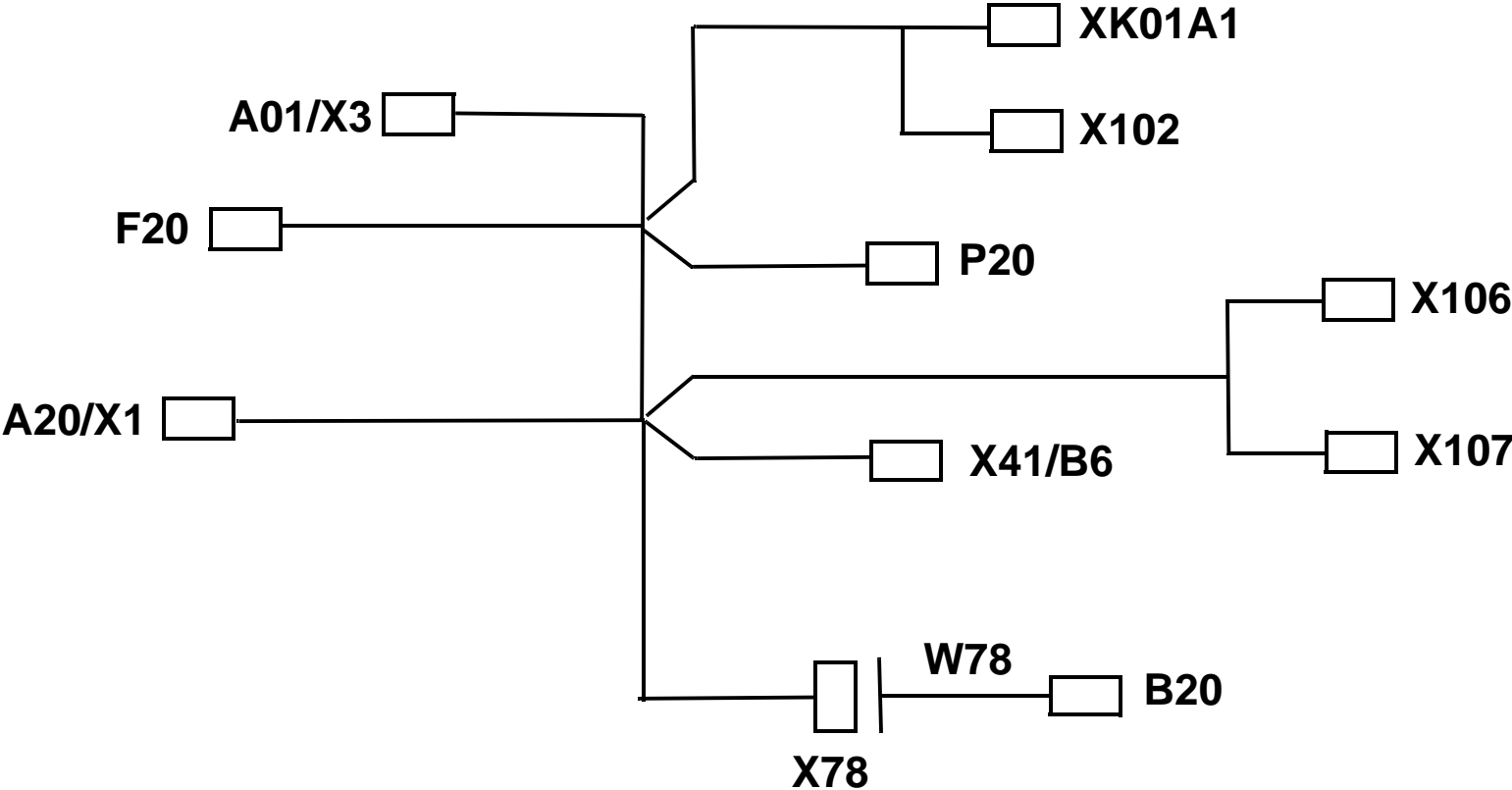

Fig. 13

2.4 Schematic diagram of the W77 cable loom (Scrubmaster B115 R)



Hako

Clean ahead

Advanced Technology for a Cleaner, Better Environment



Hako GmbH · Hamburger Str. 209-239 · D-23843 Bad Oldesloe
Fon +49 4531 806-0 · Fax +49 4531 806-338

88-10-3060 - 3288-04